

# Twister

-the leg connector



"Twister"

1 pce. of black mounting plate Ø107mm x

25mm 1 pce. of nut M8 thread

1 pce. of black linkplate Ø61mm x 9mm



Needed accessories for one set of Twister:

5 pcs. of suited mounting screws. Ø5mm screw, CSK, head diameter <10,30mm.

1 pce. of leg - any type metal or wood. Leg diameter at the Twister link plate <53mm.

M8 thread - length from 15mm to 22 mm - metal or wood leg.



Twister operates from a 90° angle to a 70° angle - 20° of steepless adjustment.

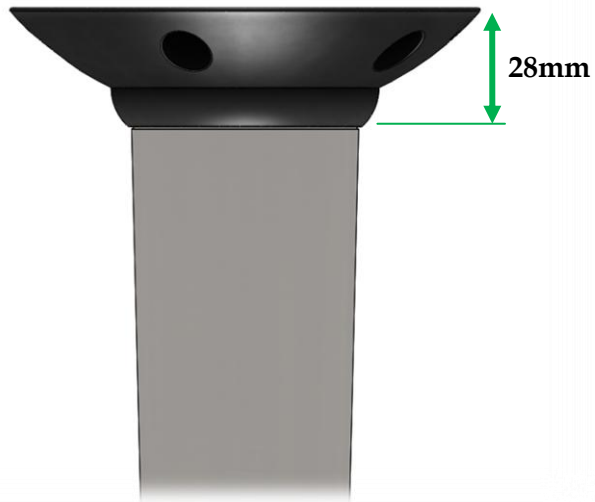

Steps when mounting:

Step #1 - Place and fasten the mounting plate.

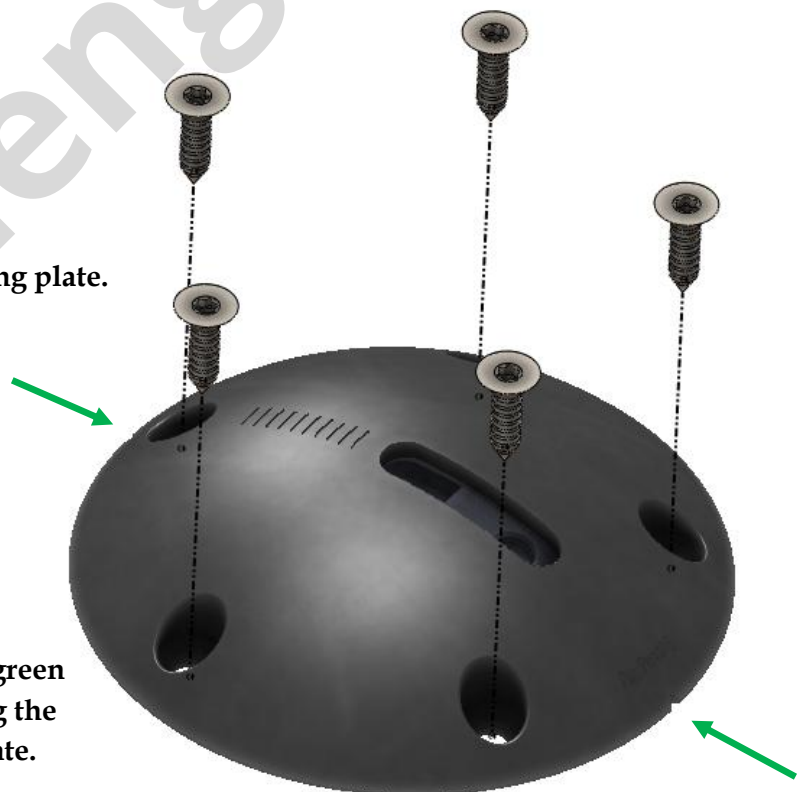

Tip : The two notches - indicated by green arrows - may be helpful when finding the optimal position for the mounting plate.

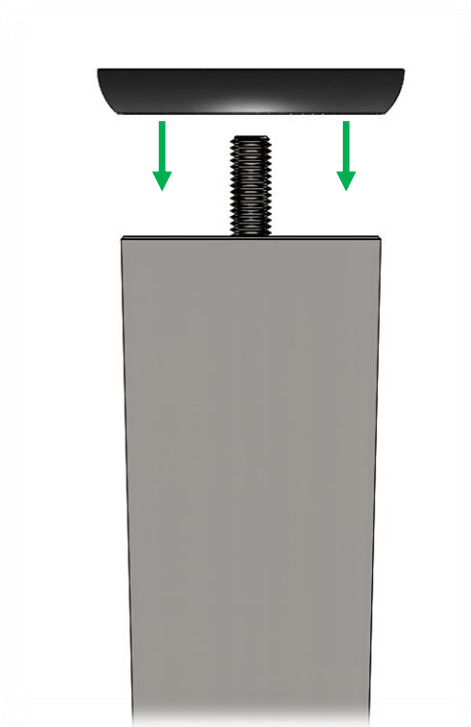

**Step #2 - Place the linkplate on top of the leg.**

**Step #3 - Tighten the leg and linkplate onto the mounting plate. Adjust and tighten in the desired angel.**

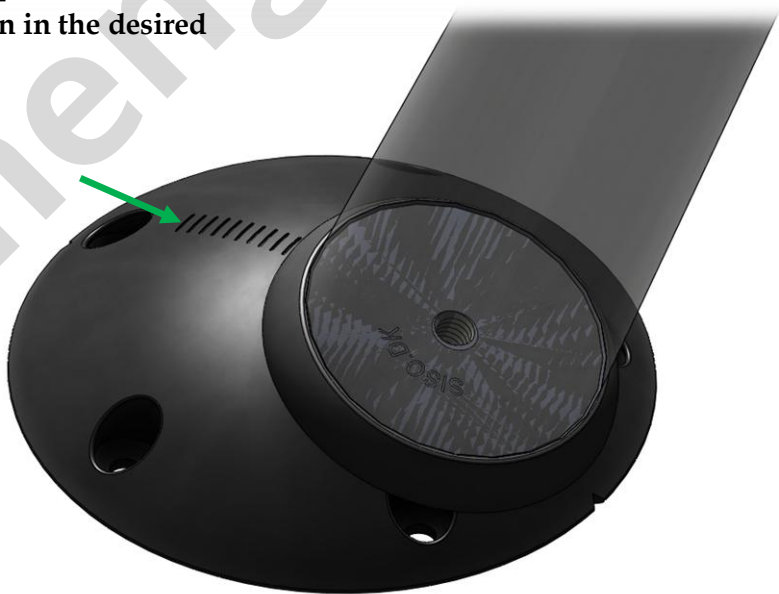

**Tip : Use the indicators on the top of the mounting plate in order to make a precise positioning of the leg. Indicated by the green arrow.**

Use the following measurements when pre-drilling.

