



Ficha técnica de produto

Technique product file / Ficha técnica de produto

Data: 14.04.2015

Versão: 1.0

IN.05.500

Dobradiças & pivots /
Hinges & pivots / Bisagras y pivotes

ET: 1439 /2015

Documento confidencial / Confidential document / Documento confidencial © JNF 2015 www.jnf.pt

Descrição / Description / Descripción

Pivot para portas vai-vem ou de batente /

Flush hinge for double action or rebated doors /

Pivote para puertas vai-ven o de batiente

Versão / Version / Versión

1.0

Data / Date / Data

14.04.2015

Material /Material / Material

Aço Inox / stainless Steel / Acero inoxidable - EN 1.4301

Acabamento / Finish / Acabado

Satinado/ Satin/ Satin

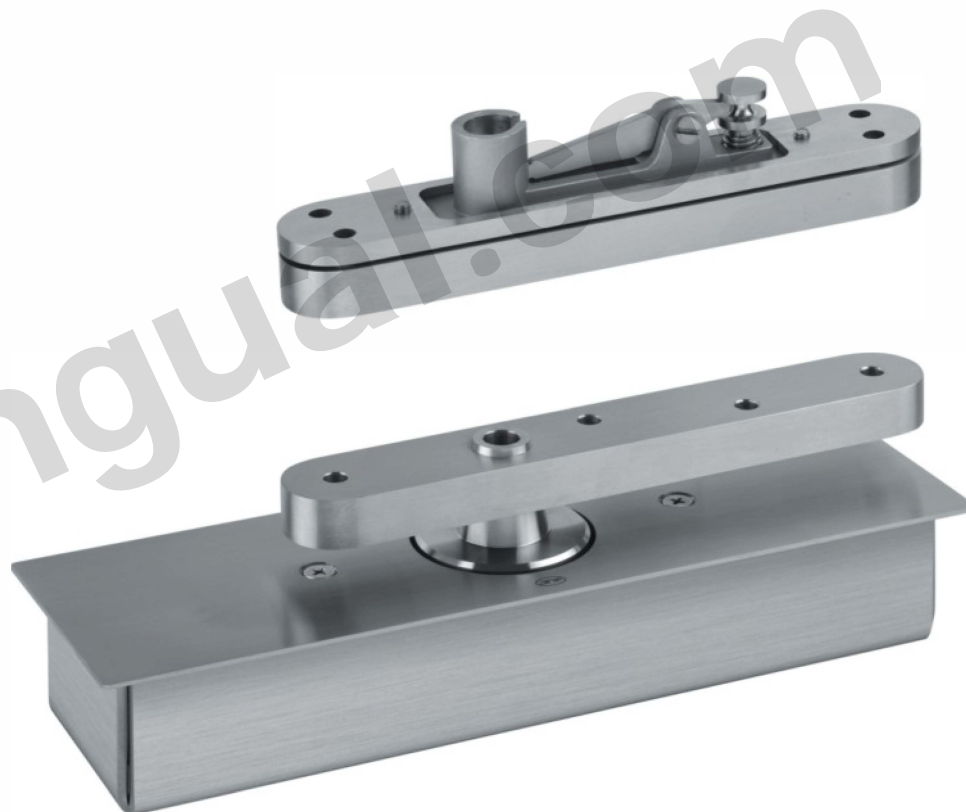



Ficha técnica de produto

Technique product file / Ficha técnica de produto

Data: 14.04.2015

Versão: 1.0

IN.05.500

Dobradiças & pivots /
Hinges & pivots / Bisagras y pivotes

ET: 1439 /2015

Documento confidencial / Confidential document / Documento confidencial © JNF 2015 www.jnf.pt

Descrição / Description / Descripción

Pivot para portas vai-ven ou de batente /

Flush hinge for double action or rebated doors /

Pivote para puertas vai-ven o de batiente

Versão / Version / Versión

1.0

Data / Date / Data

14.04.2015

Peso máx. / Max. weight / Peso max.

500 Kg

Espessura da porta /
Door thickness / Espesor de la puerta

≥40mm

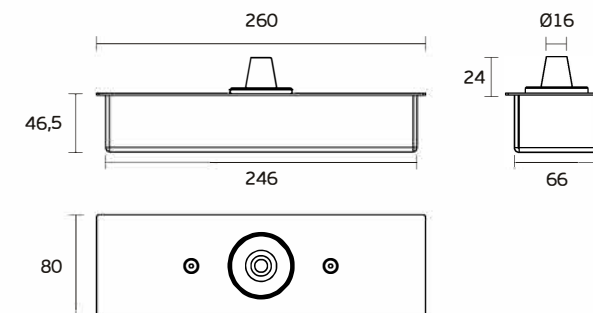
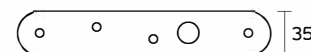
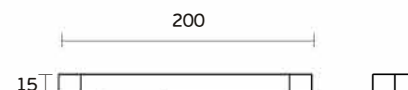
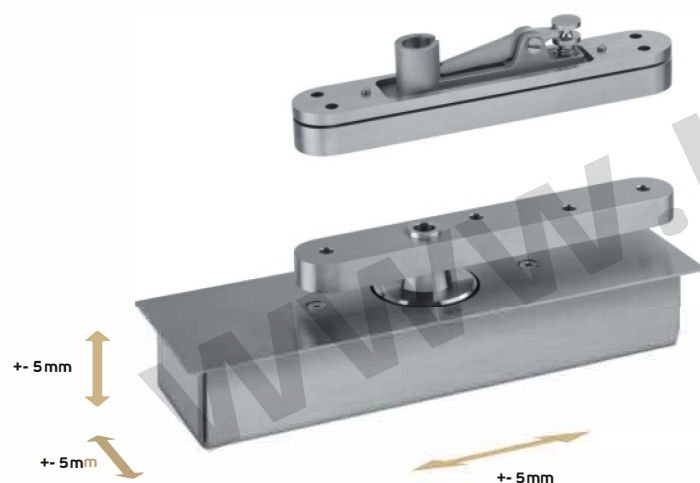



Ficha técnica de produto

Technique product file / Ficha técnica de produto

Data: 14.04.2015

Versão: 1.0

IN.05.500

Dobradiças & pivots /

Hinges & pivots / Bisagras y pivotes

ET: 1439 /2015

Documento confidencial / Confidential document / Documento confidencial © JNF 2015 www.jnf.pt

Descrição / Description / Descripción

Pivot para portas vai-vem ou de batente /

Flush hinge for double action or rebated doors /

Pivote para puertas vai-ven o de batiente

Versão / Version / Versión

1.0

Data / Date / Data

14.04.2015

Peso máx. / Max. weight / Peso max.

500 Kg

Espessura da porta /
Door thickness / Espesor de la puerta

≥40mm

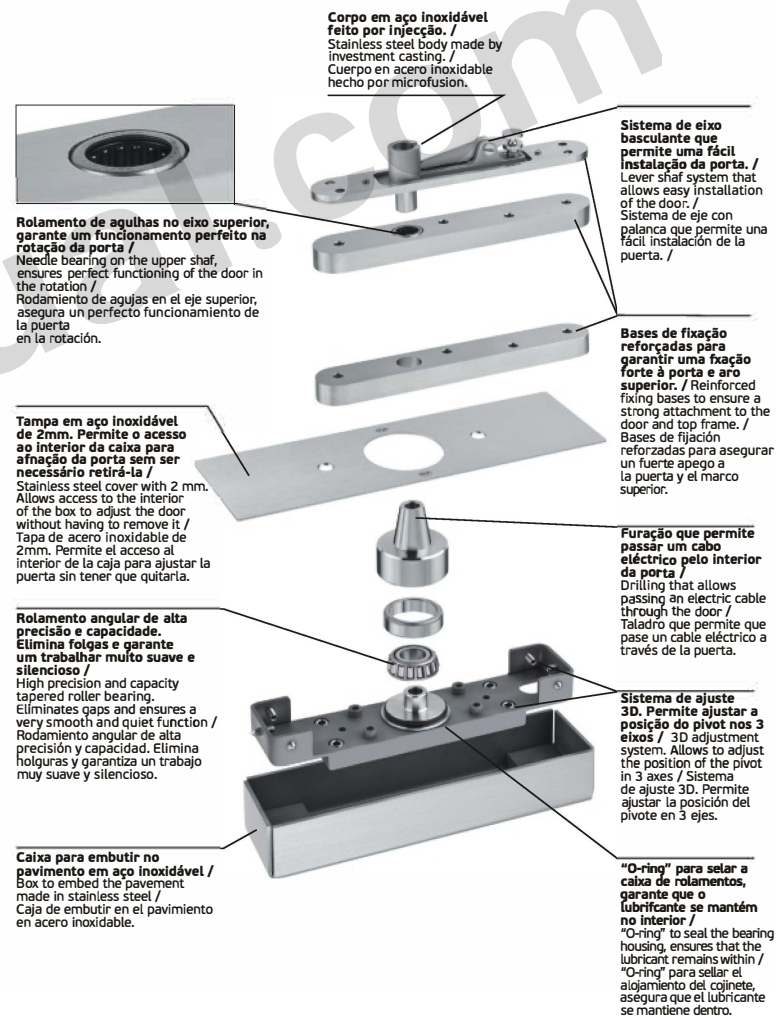

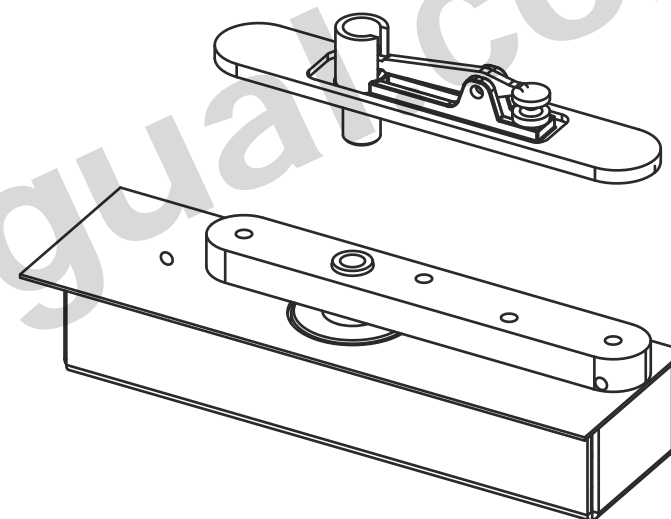

IN.05.500

PIVOT PARA PORTAS VAI-DEM OU DE BATEMTE /
FLUSH HINGE FOR DOUBLE ACTION OR REBATED DOORS /
PIVOT POUR PORTES DE DOUBLE ACTION OU DE BATEMTE /
PIVOTE PARA PUERTAS VAI-DEM O DE BATEMTE



J. Neves & Filhos
Comrcio e Indstria de Ferragens, S.A.

Rua das Mimosas, 849/851
Zona Industrial das Mimosas
S. Pedro da Cova | Ap. 75
4424-909 Gondomar PORTUGAL

jnf@jnf.pt | www.jnf.pt

