

 **MENGUAL**<sup>®</sup>

 **ITALIANA**<sup>®</sup>  
f e r r a m e n t a

*Rekord Tech*

LEVELLERS





## REKORD TECH



REKORD TECH is a development of the REKORD levellers. REKORD TECH is a concealed leveller to be fixed in the side panels and is suitable for heavy duty wardrobes, bookcases and modular furniture, as well as for flat-pack furniture. It is available in two versions: with rectangular base for side panels with 16mm minimum thickness or with round base for side panels with 18mm minimum thickness. The round base version can be completely embedded by operating a doublediameter hole. REKORD TECH is installed into the bottom edge of the side panel and it is then adjustable through a  $\varnothing 6$  mm hole from the inside, by using a S4 mm allen wrench. Even with a loaded cabinet, the adjustment is easy and smooth. REKORD TECH is available in multiple heights, with a maximum adjustment range of 25mm. In any case, all versions grant a capacity loading of 150 Kg each.

150 Kg per piece



REKORD TECH  
Rectangular base

### INSTALLATION

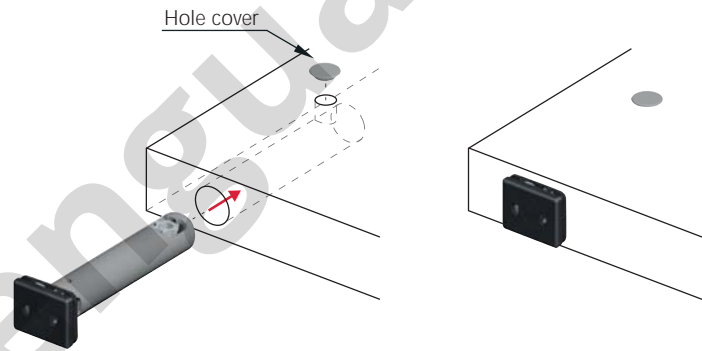
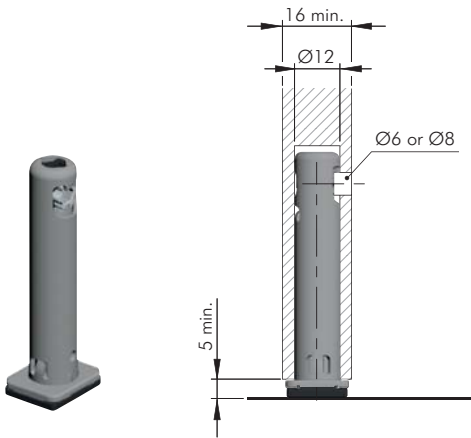

REKORD TECH  
Round base

### INSTALLATION

#### Standard installation

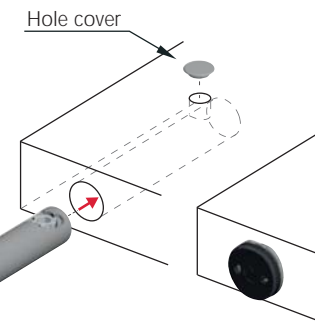

#### Suitable for fully embedded installation

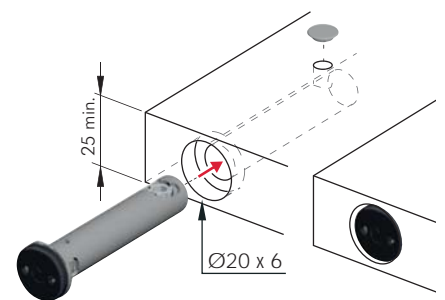

### ADJUSTMENTS

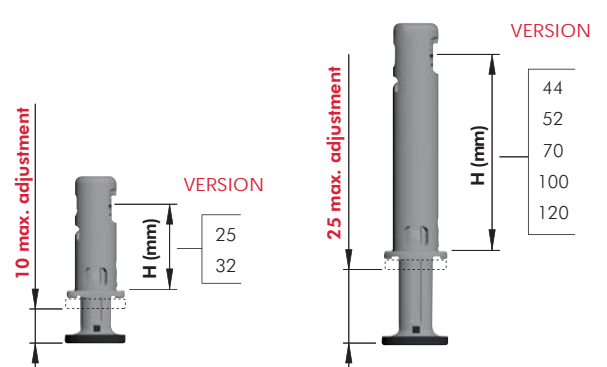
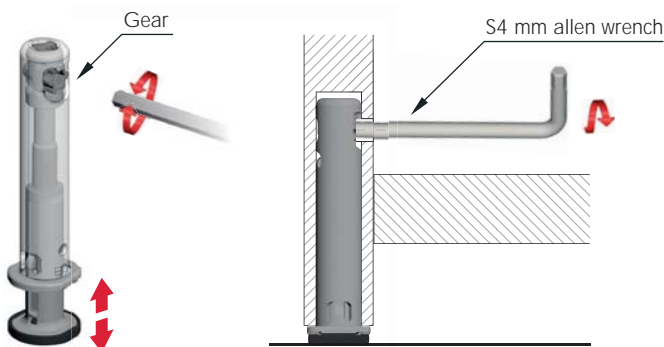



**REKORD TECH H 25 mm**

Rectangular base

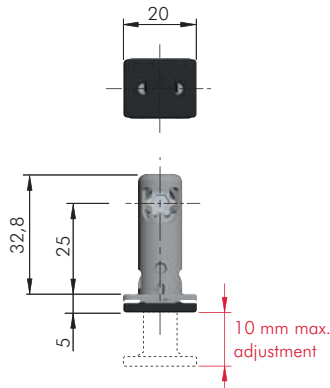
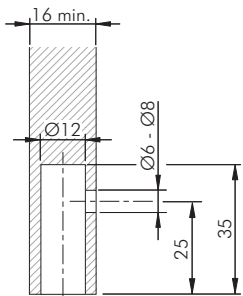

= S4  
 ZA ST EP = --- pcs.  
 123   
**3030301000**

Round base

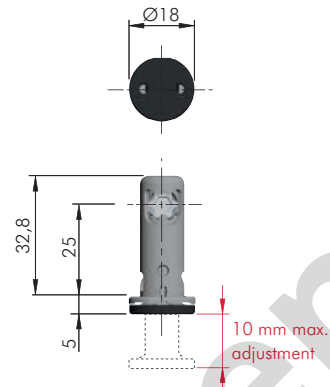
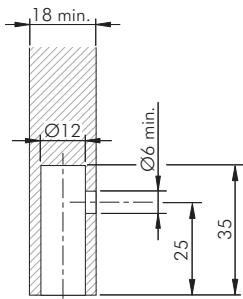

= S4  
 ZA ST EP = --- pcs.  
 123   
**3030311000**

**REKORD TECH H 32 mm**

Rectangular base

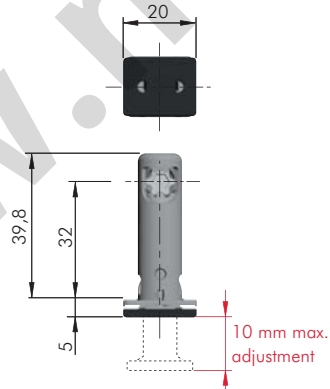
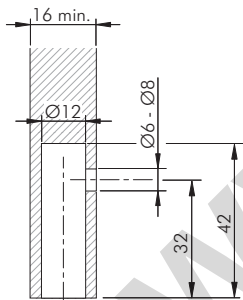

= S4  
 ZA ST EP = --- pcs.  
 123   
**3030302000**

Round base

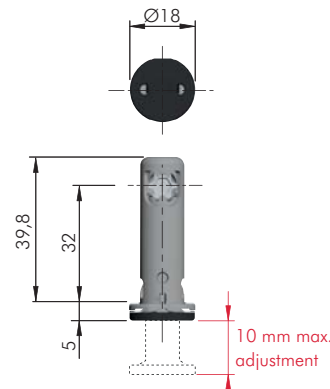
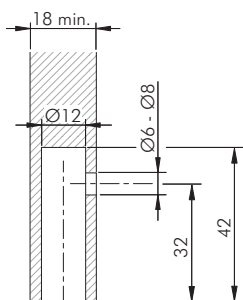

= S4  
 ZA ST EP = --- pcs.  
 123   
**3030312000**



## REKORD TECH H 44 mm

### Rectangular base

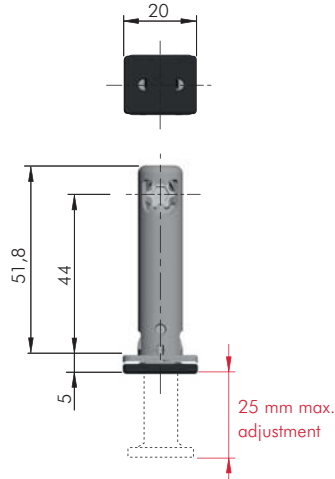
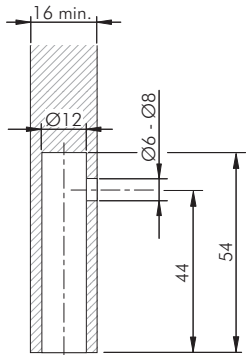

|            |            |
|------------|------------|
| = S4       | = --- pcs. |
| ZA EP ST   |            |
| 123        |            |
| 3030303000 |            |

### Round base

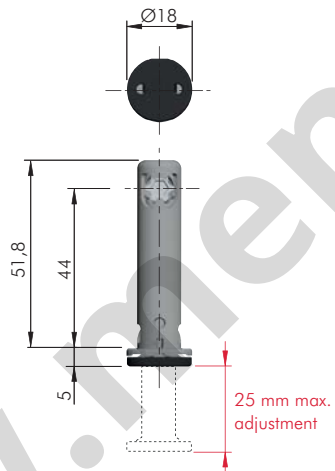
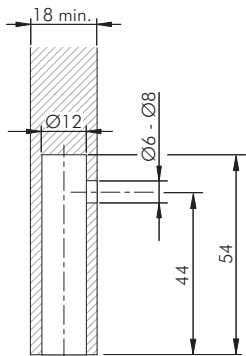

|            |            |
|------------|------------|
| = S4       | = --- pcs. |
| ZA ST EP   |            |
| 123        |            |
| 3030313000 |            |

## REKORD TECH H 52 mm

### Rectangular base

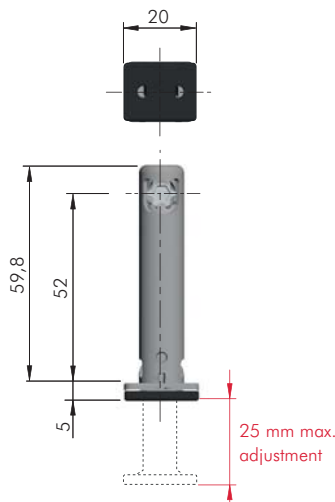
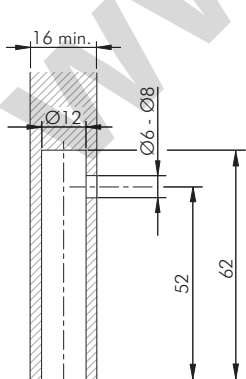

|            |            |
|------------|------------|
| = S4       | = --- pcs. |
| ZA ST EP   |            |
| 123        |            |
| 3030304000 |            |



Round base

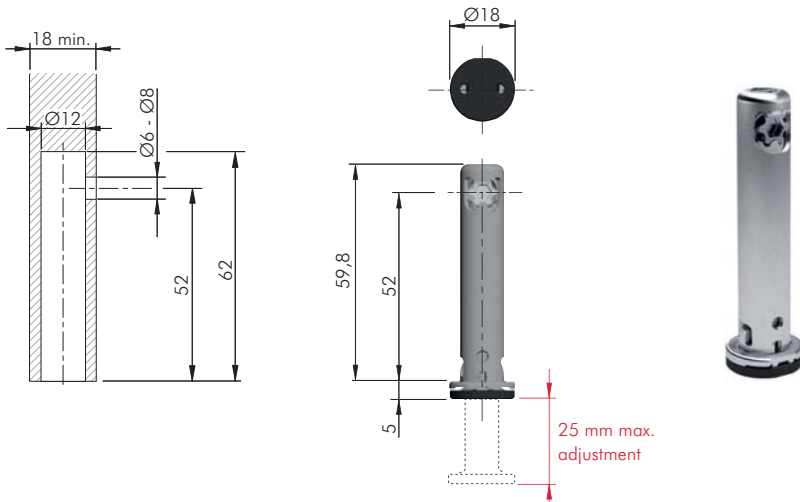

|            |            |
|------------|------------|
| = S4       | = --- pcs. |
| ZA ST EP   |            |
| 123        |            |
| 3030314000 |            |

REKORD TECH H 70 mm

Rectangular base

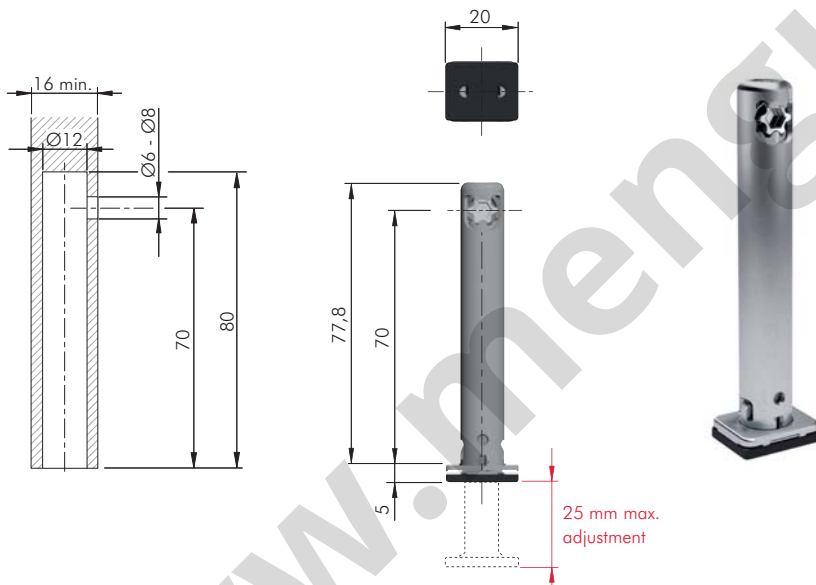

|            |            |
|------------|------------|
| = S4       | = --- pcs. |
| ZA ST EP   |            |
| 123        |            |
| 3030305000 |            |

Round base

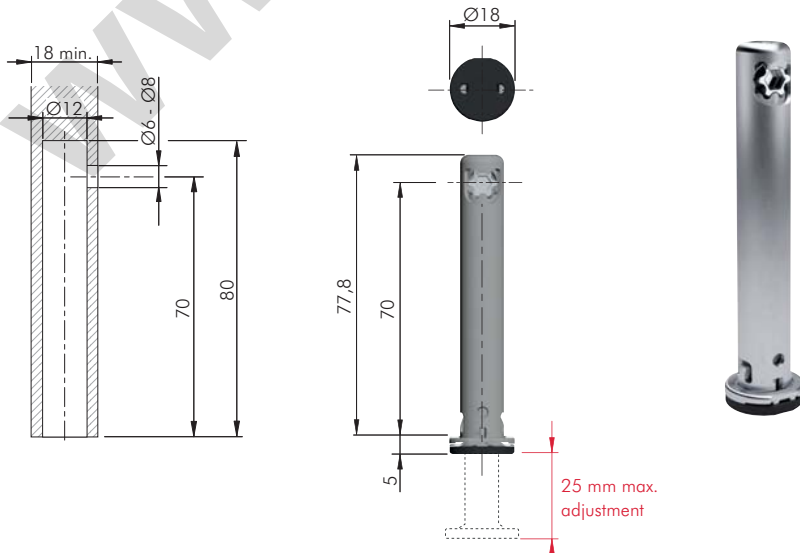

|            |            |
|------------|------------|
| = S4       | = --- pcs. |
| ZA ST EP   |            |
| 123        |            |
| 3030315000 |            |



## REKORD TECH H 100 mm

### Rectangular base

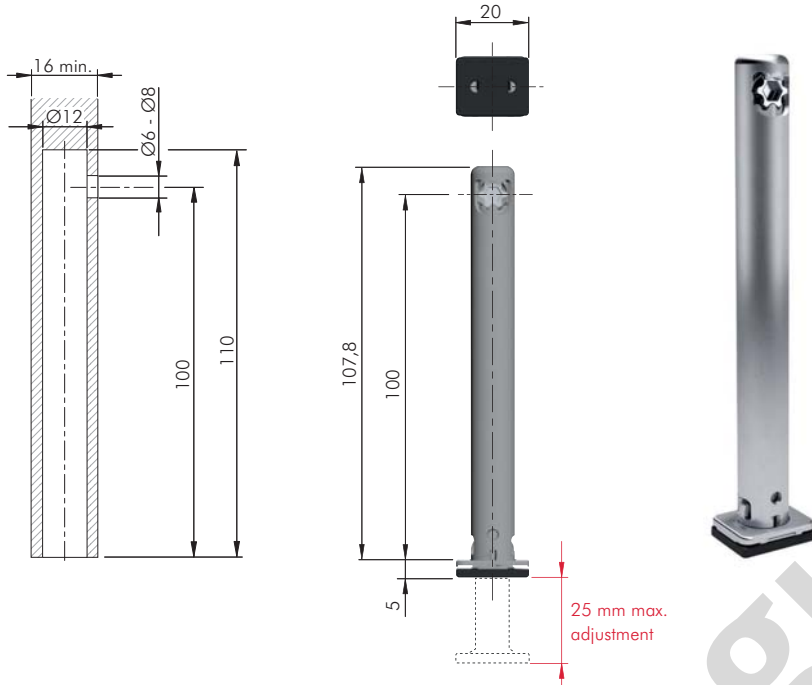

|            |            |
|------------|------------|
| = S4       | = --- pcs. |
| ZA ST EP   |            |
| 123        |            |
| 3030306000 |            |

### Round base

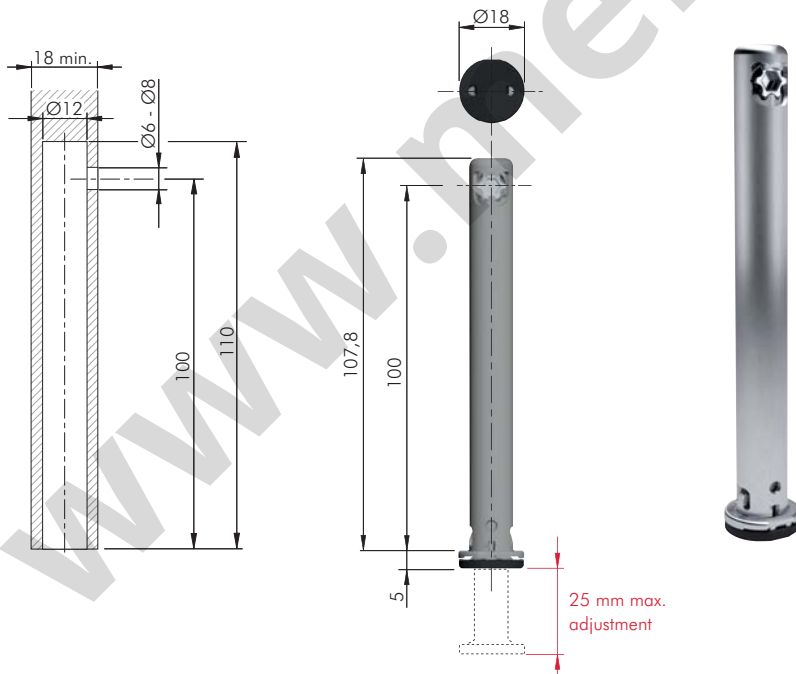

|            |            |
|------------|------------|
| = S4       | = --- pcs. |
| ZA ST EP   |            |
| 123        |            |
| 3030316000 |            |



REKORD TECH H 120 mm

Rectangular base

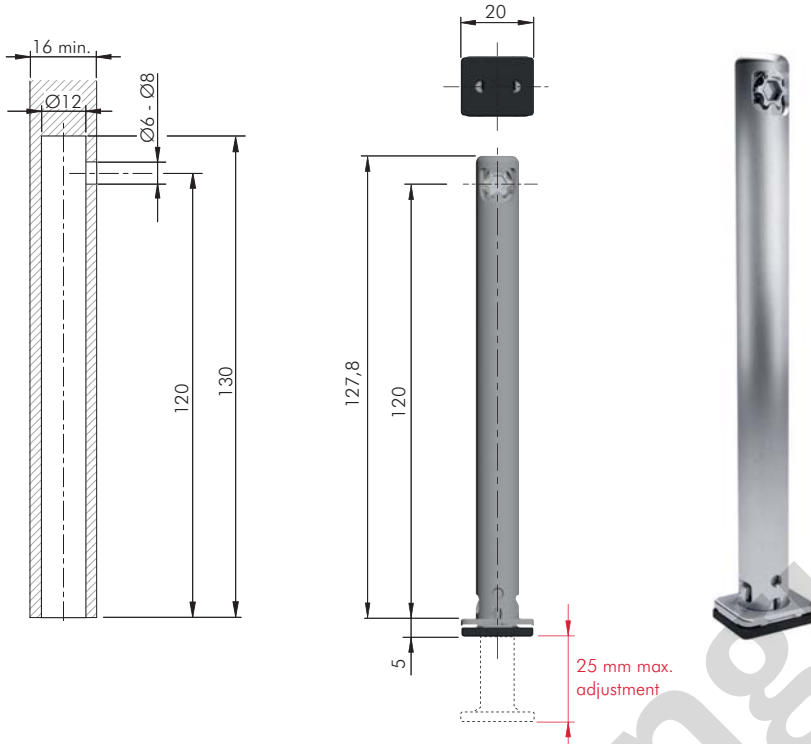

|            |      |  |            |
|------------|------|--|------------|
|            | = S4 |  | = --- pcs. |
|            |      |  |            |
|            |      |  |            |
| 3030307000 |      |  |            |

Round base

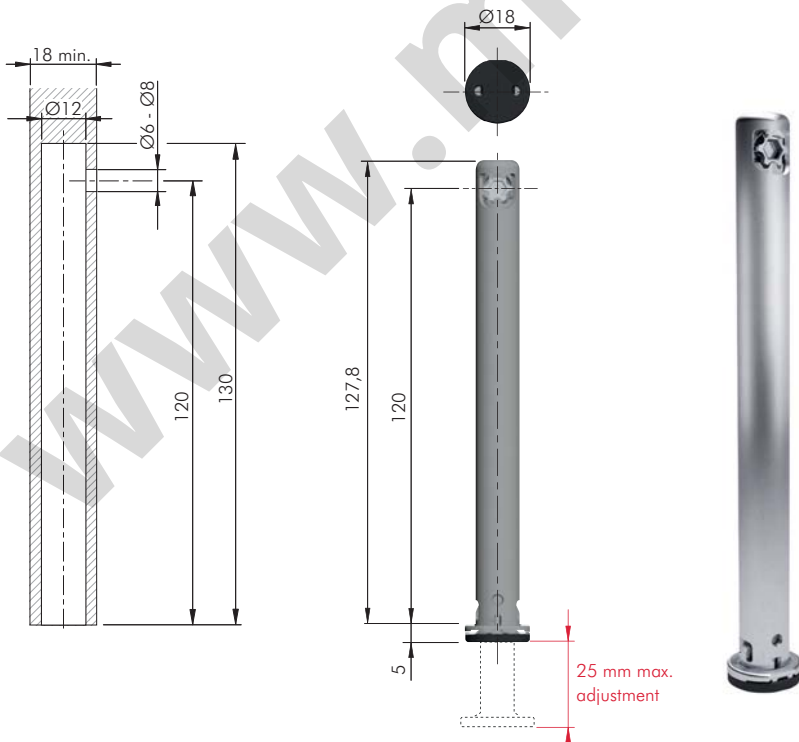

|            |      |  |            |
|------------|------|--|------------|
|            | = S4 |  | = --- pcs. |
|            |      |  |            |
|            |      |  |            |
| 3030317000 |      |  |            |



## REKORD TECH ACCESSORY

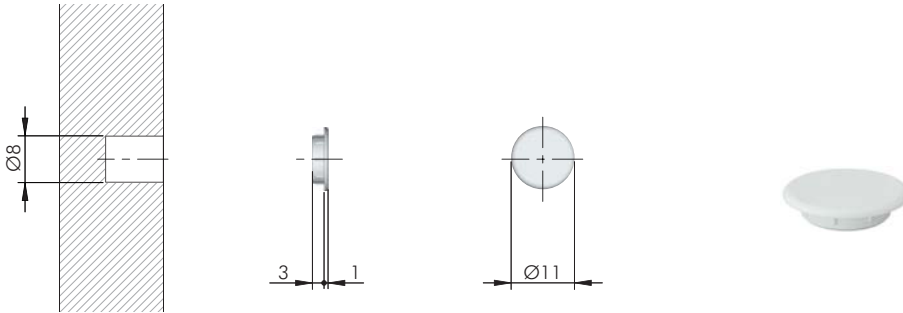

= Ø 8 mm      +

     = 5000 pcs.

23002010AB

## DRILL BITS FOR REKORD TECH

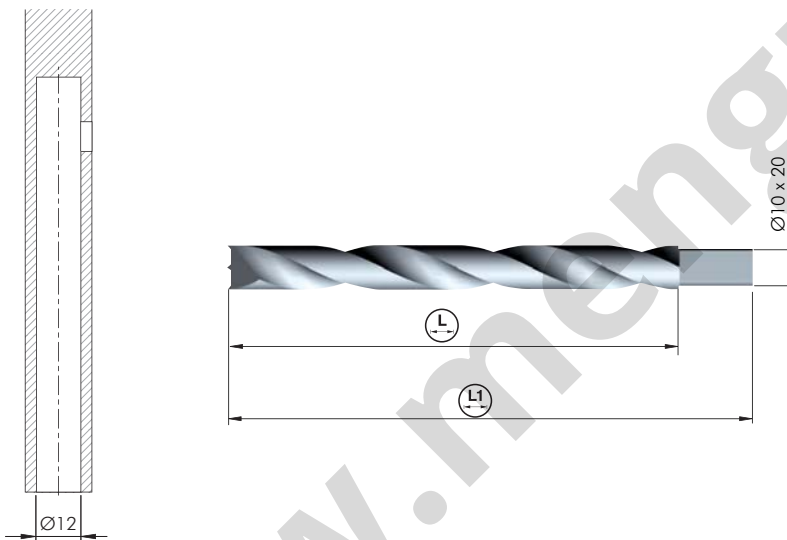

HSS      = on request

|            |     |     | Rekord Tech version  |
|------------|-----|-----|----------------------|
| -----      | 60  | 80  | H 25<br>H 32<br>H 44 |
| 3030158000 | 78  | 98  | H 52                 |
| 3030159000 | 96  | 116 | H 70                 |
| 3030153000 | 122 | 142 | H 100                |
| 3030152000 | 146 | 166 | H 120                |

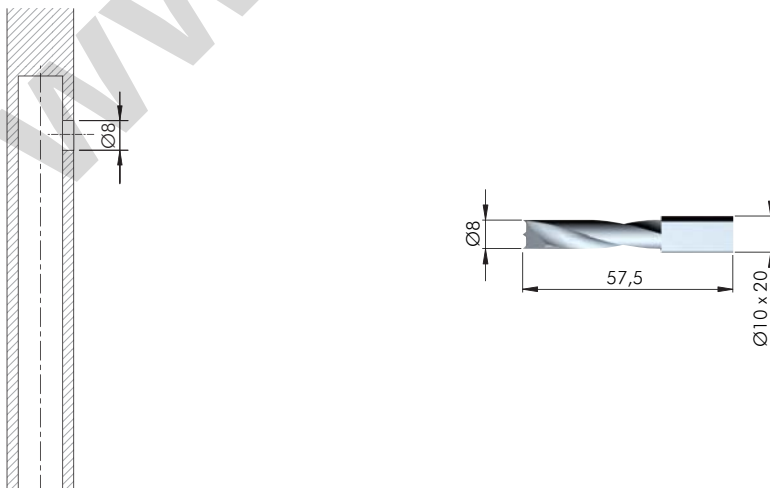

HSS      = on request

1145202000





**DRILLING JIG FOR REKORD TECH**

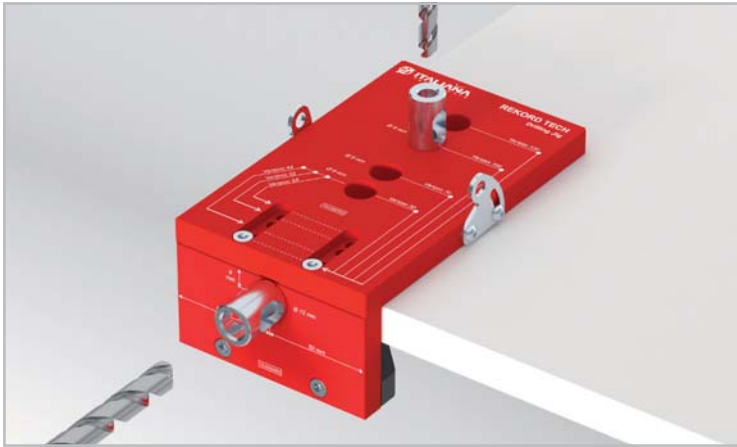

GENERAL SPECIFICATIONS

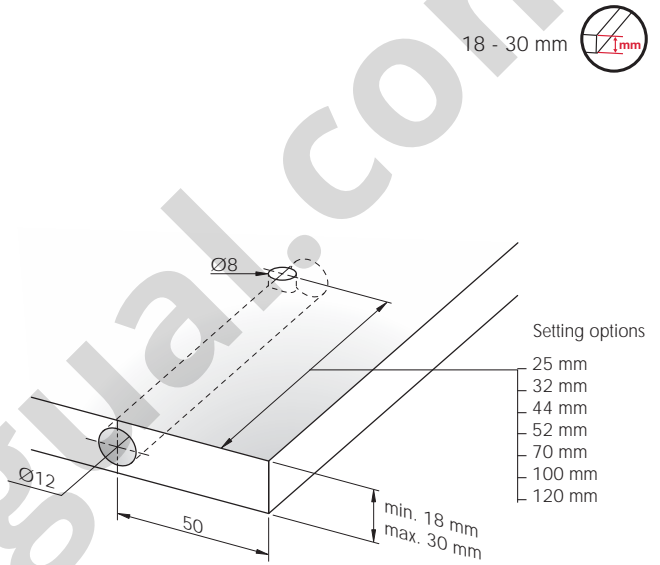
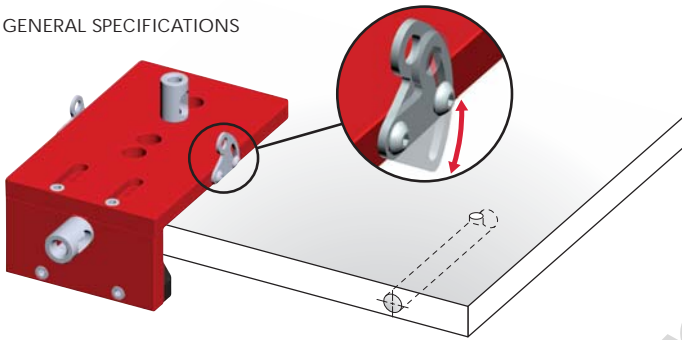

Setting options

- 25 mm
- 32 mm
- 44 mm
- 52 mm
- 70 mm
- 100 mm
- 120 mm

SETTINGS FOR DIFFERENT REKORD TECH VERSIONS

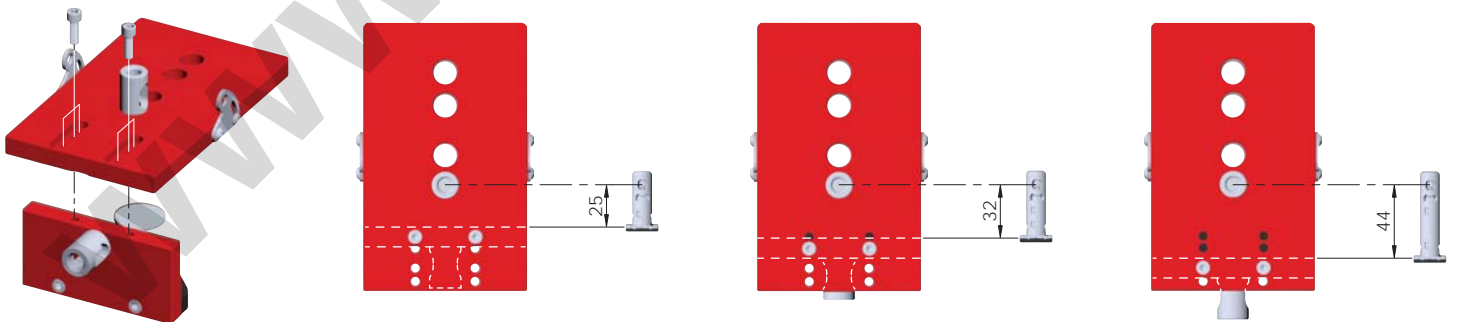
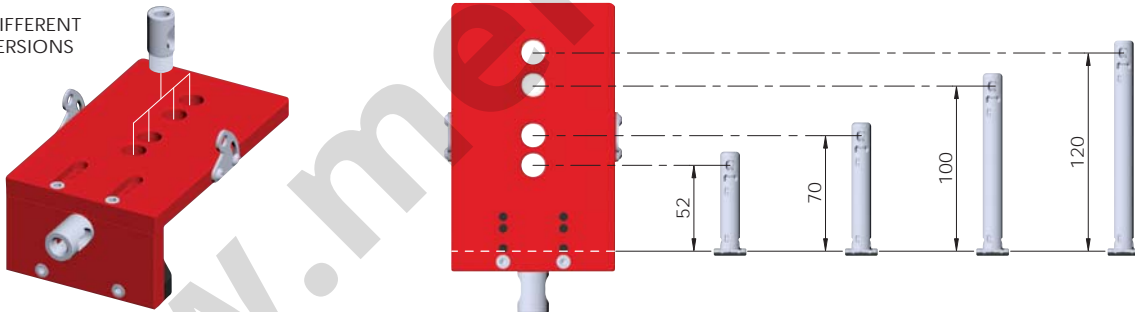

DRILLING SPACERS FOR OTHER PANEL THICKNESSES

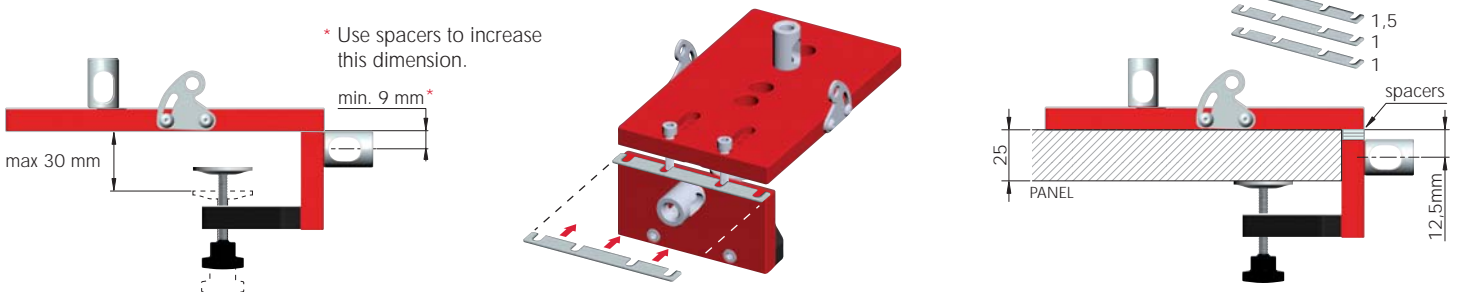



REKORD TECH DRILLING JIG FOR PANEL THICKNESS 18 - 25 mm

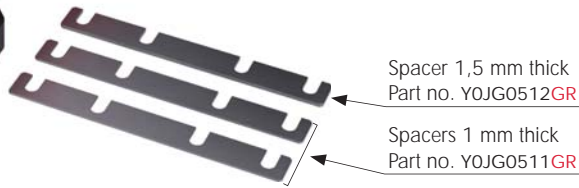
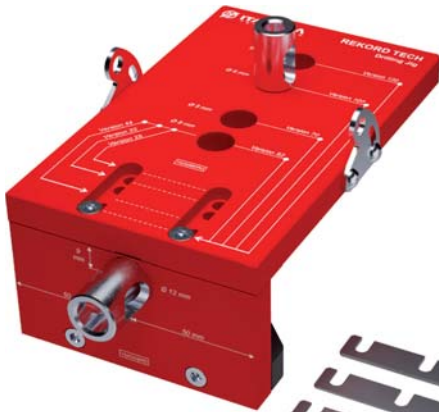

Spacer 1,5 mm thick  
Part no. YOJG0512GR

Spacers 1 mm thick  
Part no. YOJG0511GR

|            |    |    |              |
|------------|----|----|--------------|
| AL         | ST | EP | = on request |
|            |    |    |              |
| YOJG0122RO |    |    |              |

NOTE: The product code includes all the components shown in the picture.

REKORD 12 DRILLING JIG ACCESSORIES

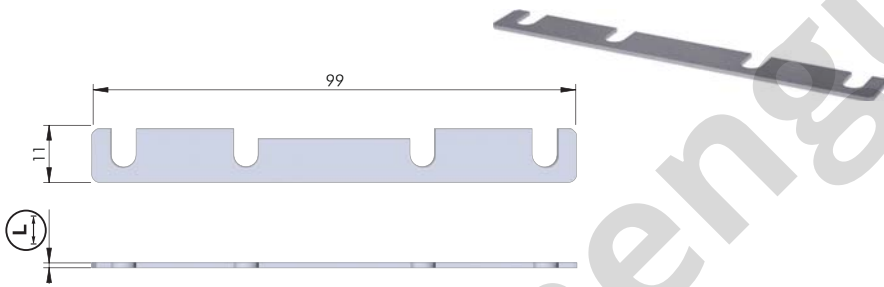

|            |              |
|------------|--------------|
| AL         | = on request |
|            |              |
| YOJG0511GR | 1            |
| YOJG0512GR | 1,5          |

DRILLING JIG DEPTH STOP COLLARS



|            |              |
|------------|--------------|
| ST         | = on request |
|            |              |
| YOJG051700 | Ø8           |
| YOJG051900 | Ø12          |

DRILL BIT

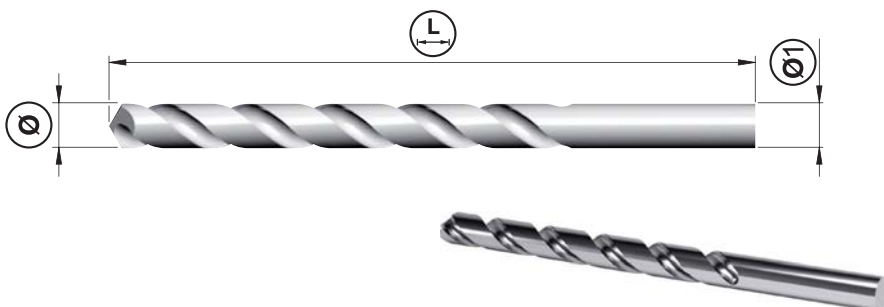

|            |              |     |     |
|------------|--------------|-----|-----|
| HSS        | = on request |     |     |
|            |              |     |     |
| YOJG052800 | Ø8           | 117 | Ø8  |
| YOJG054700 | Ø12          | 205 | Ø10 |

NOTE: For drilling jig we recommend to use precision-