

BLUMOTION

by Blum

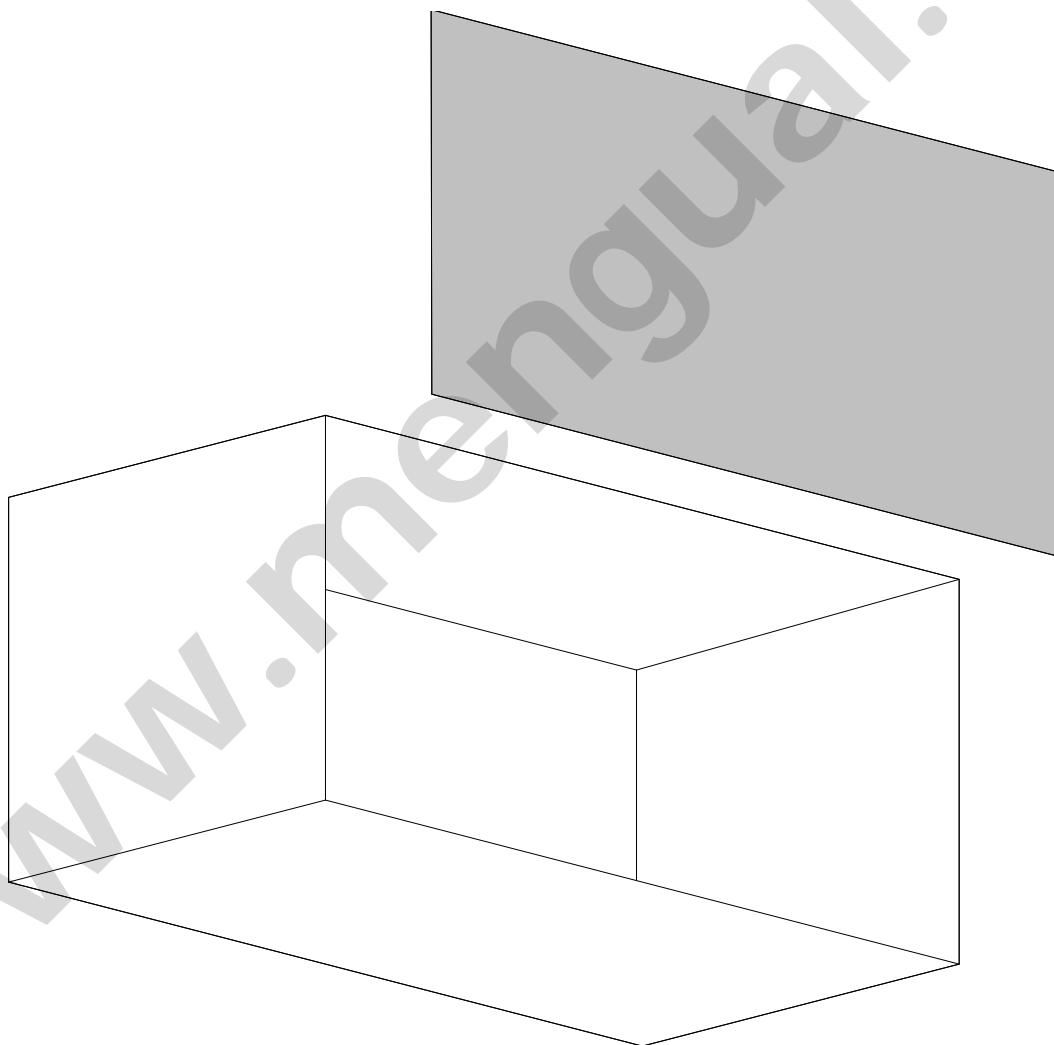

# AVENTOS HL top

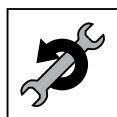
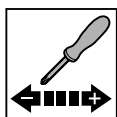
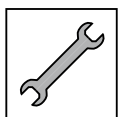



Standardanwendungen | Standard applications | Applications standard | Applicazioni standard | Aplicaciones estándar |  
Rozwiązania standardowe | Стандартные конструкции | 标准应用

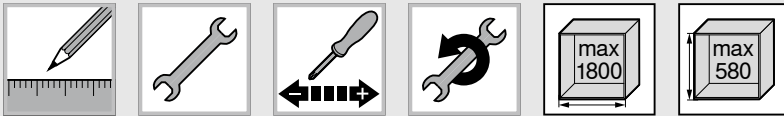

Sonderanwendungen | Special applications | Applications spéciales | Applicazioni speciali | Aplicaciones especiales |  
Rozwiązania specjalne | Специальные конструкции | 特殊应用

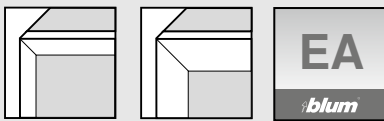

<http://www.blum.com/eaapp>



Planung | Planning | Planification |  
Progettazione | Planificación |  
Planowanie | Проектирование | 设计

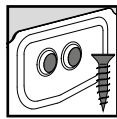

Spax-Schraube | chipboard screw  
| Vis Spax | Vite te per truciolare |  
Tornillo aglio | Wkręt do płyty wiórowej |  
Саморезы Spax | 木工螺丝

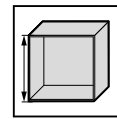

Korpshöhe | Cabinet height | Hauteur corps  
de meuble | Altezza corpo mobile | Altura  
de cuerpo de mueble | Wysokość korpusu |  
Высота корпуса | 柜体高度

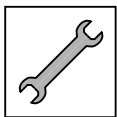

Montage | Assembly | Montage |  
Montaggio | Montaje | Montaž |  
Монтаж | 安装

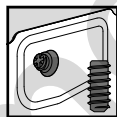

Systemschrauben | System screw |  
Eurovis | Vite EURO | Tornillo Euro |  
System wkrętów | Евровинт | 系统螺丝

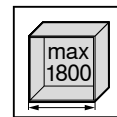

Korpusbreite | Cabinet width | Largeur corps  
de meuble | Larghezza corpo mobile | Ancho  
de cuerpo de mueble | Szerokość korpusu |  
Ширина корпуса | 柜体宽度



Einstellung | Adjustment | Réglage |  
Regolazione | Ajuste | Regulacja |  
Регулировка | 调节

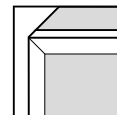

Schmaler Alurahmen | Narrow alu frame |  
Cadre alu étroit | Tela in alluminio stretti |  
Marcos de aluminio estrechos |  
Wąskie ramki aluminiowe |  
Узкая алюминиевая рамка |  
窄边铝框面板

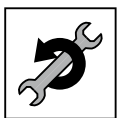

Demontage | Removal | Démontage |  
Smontaggio | Desmontaje |  
Демонтаж | 拆卸

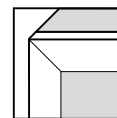

Breiter Alurahmen | Wide alu frame |  
Cadre alu large | Tela in alluminio larghi |  
Marcos de aluminio anchos |  
Szerokie ramki aluminiowe | Широкая  
алюминиевая рамка | 宽边铝框面板



Klickbar | Clickable | Cliquable |  
Cliccabile | Se puede hacer clic |  
Klikalny | Кликабельно | 可点击

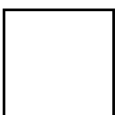

Nicht Klickbar | Not clickable |  
Pas cliquable | Non cliccabile |  
No se puede hacer clic |  
Nie klikalny | Некликабельно |  
不可点击



Zurück | Back | Retour | Indietro |  
Hacia atrás | Wstecz | Назад | 返回

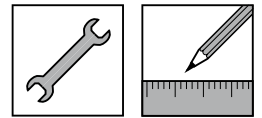

**WARNING | WARNING | AVERTISSEMENT | AVVERTENZA |  
ADVERTENCIA | OSTRZEŻENIE | ВНИМАНИЕ | 警告**

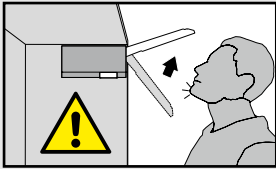

Verletzungsgefahr durch hochspringenden Hebel!  
Arms can spring upwards, causing injury.  
Risque de blessure en cas de relevage brusque du levier!  
Pericolo di lesioni a causa del possibile scatto della leva verso l'alto!

Peligro de lesión por elevación de la palanca!  
Niebezpieczeństwo zranienia przez gwałtownie unoszący się podnośnik!  
Существует опасность получения травмы при выскакивании рычага!  
アームが跳ね上がって重傷を負う可能性があります。  
伸縮臂上弾会伤人!

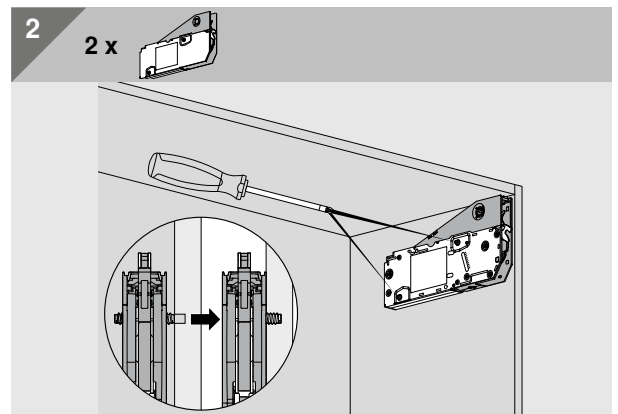
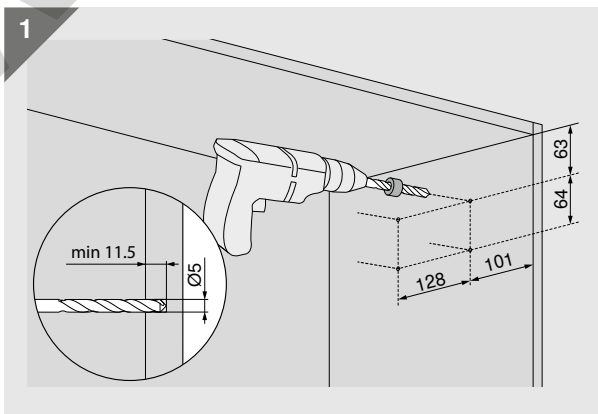
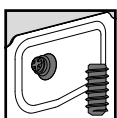
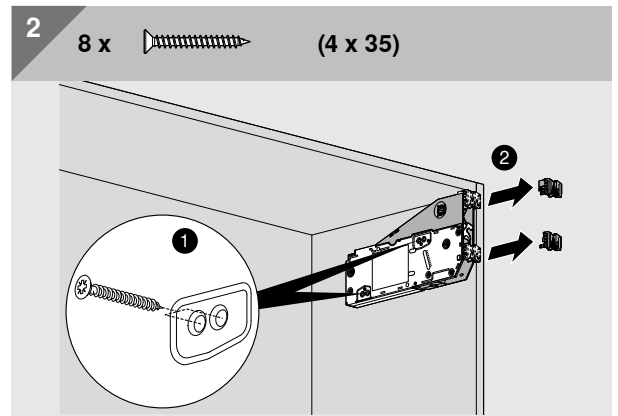
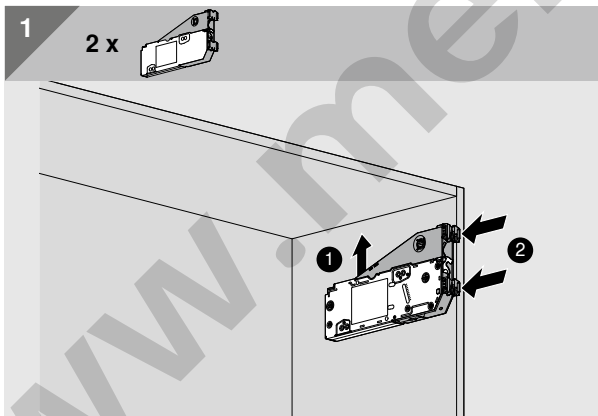
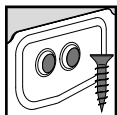
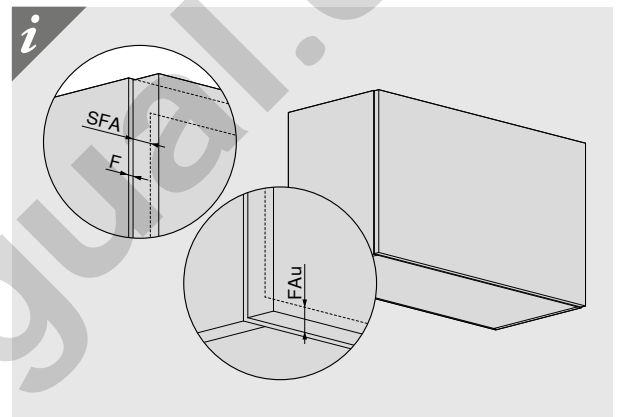
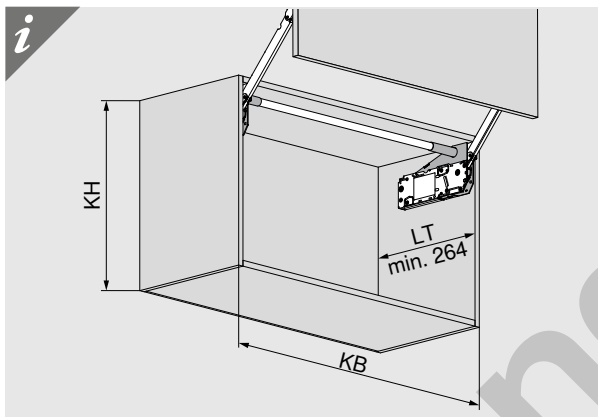
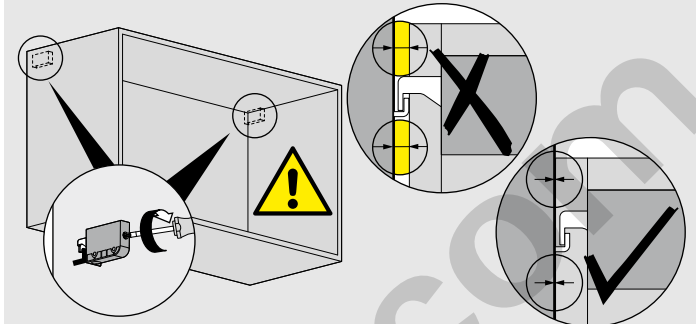

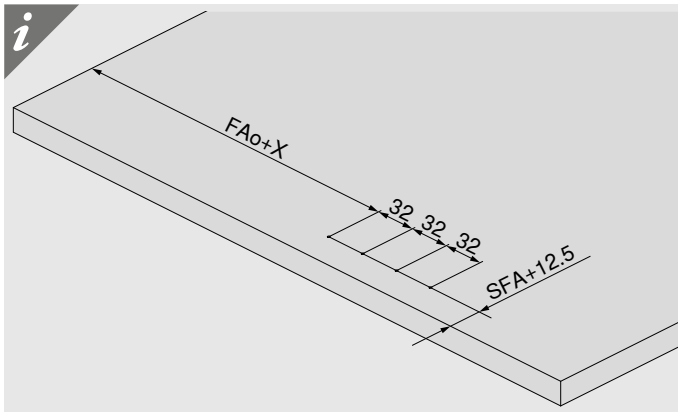
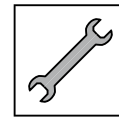

**i**

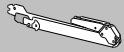
	x
22L320x (KH 300-340)	113
22L350x (KH 340-390)	153
22L380x (KH 390-540)	203
22L390x (KH 480-580)	256

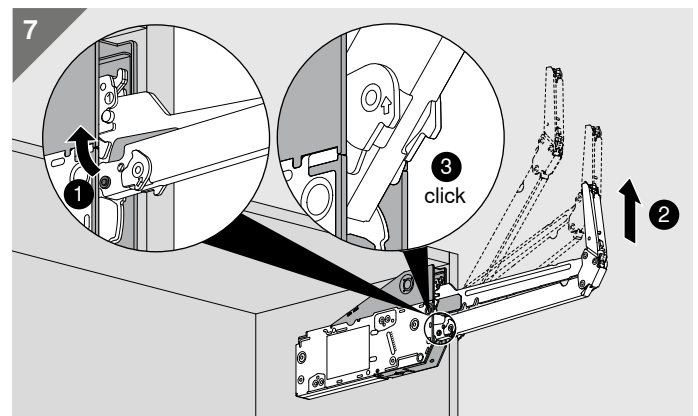
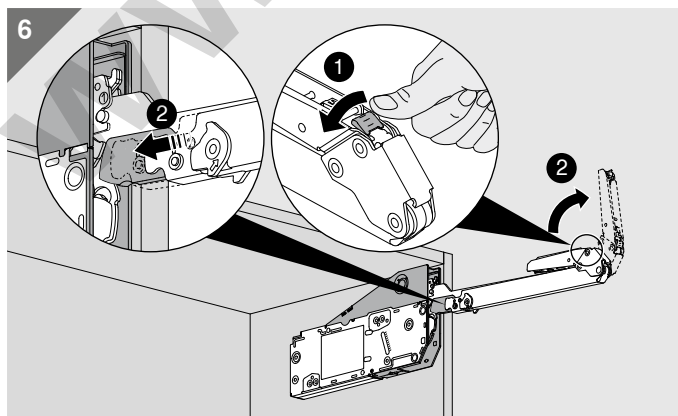
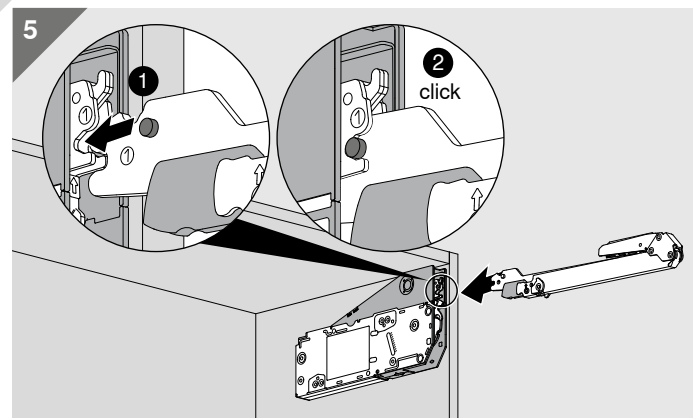
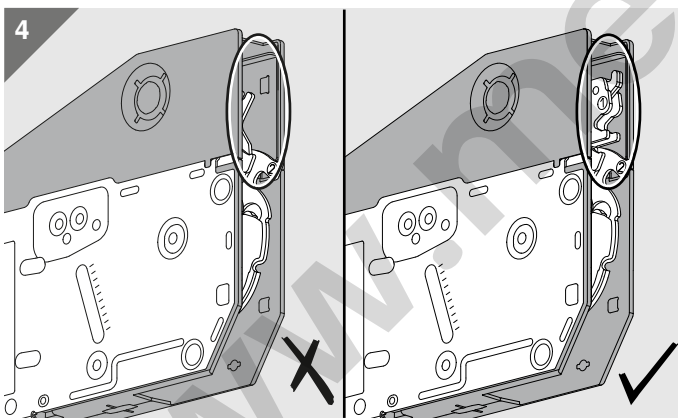
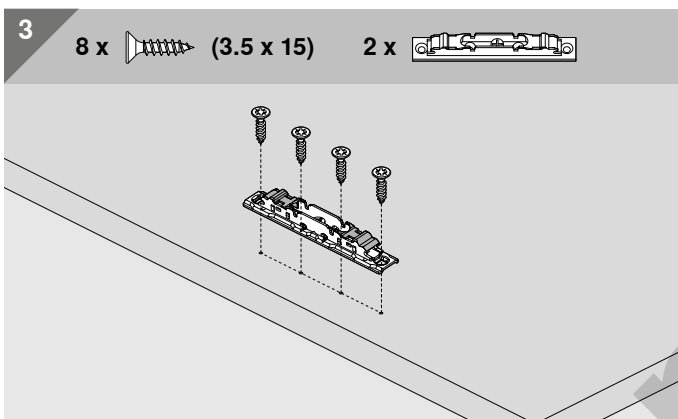

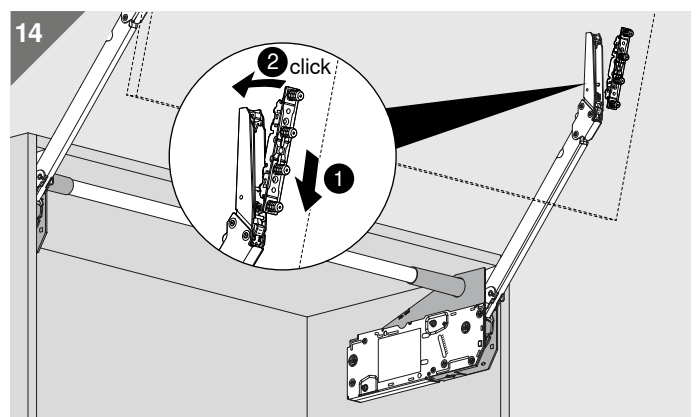
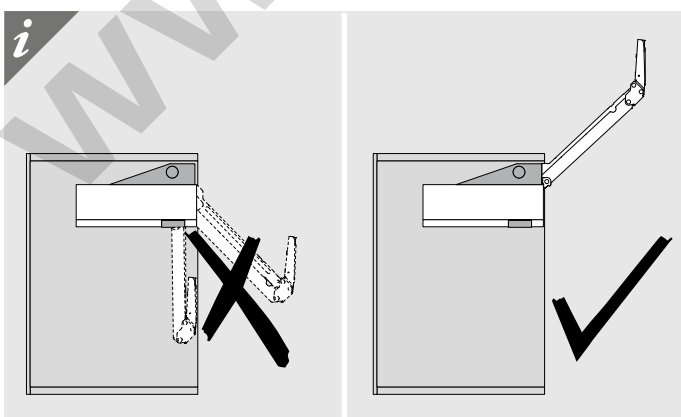
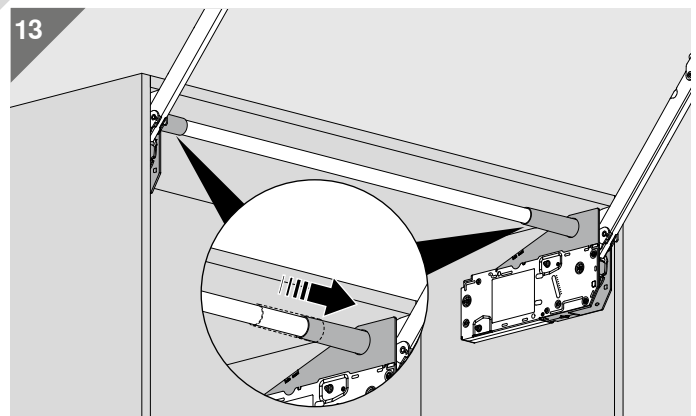
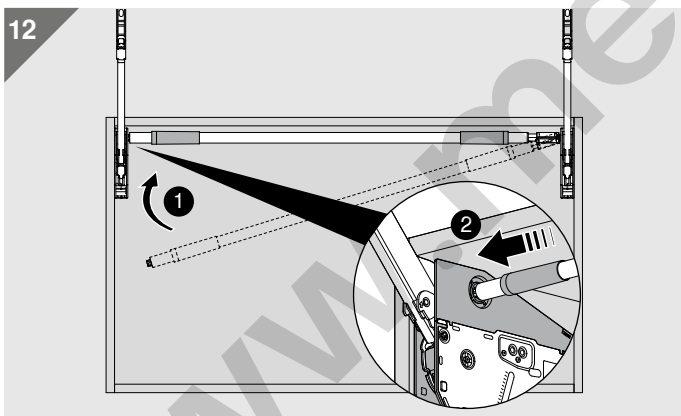
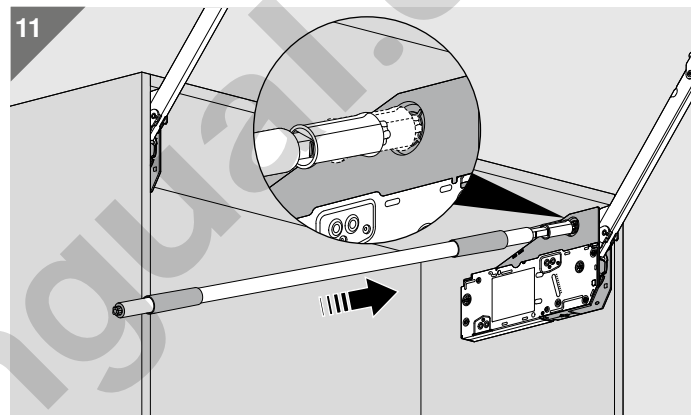
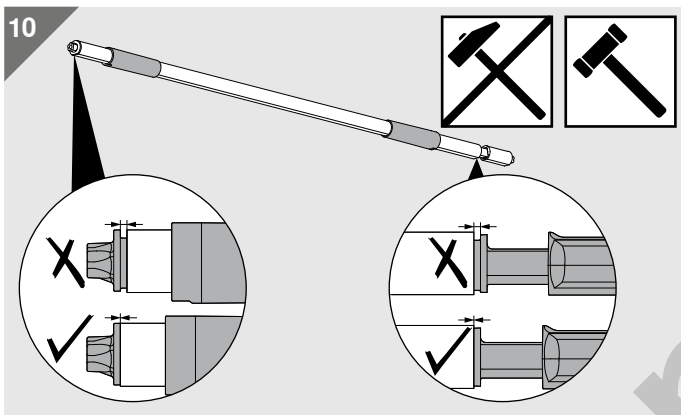
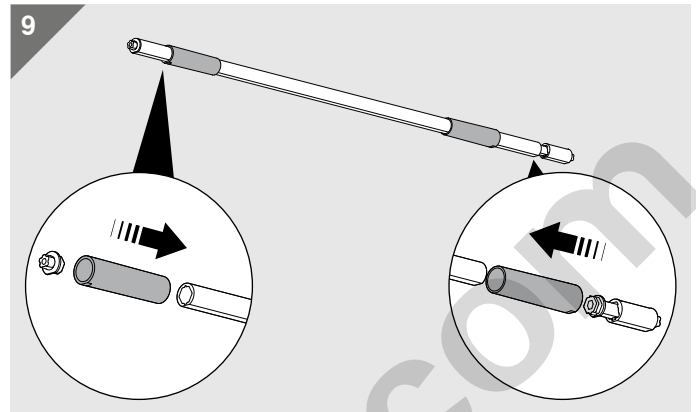
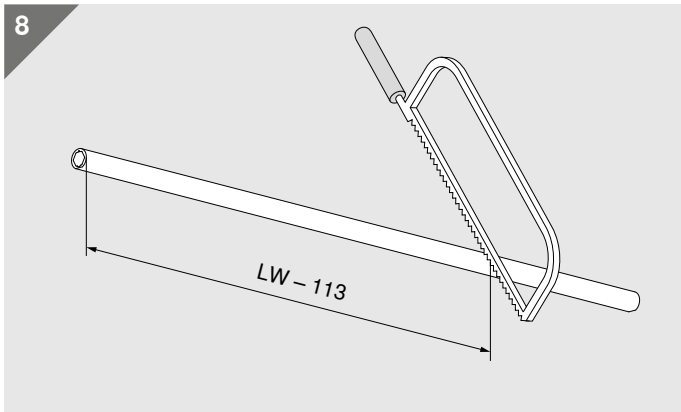

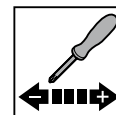

**WARNING | WARNING | AVERTISSEMENT | AVVERTENZA |  
ADVERTENCIA | OSTRZEŻENIE | ВНИМАНИЕ | 警告**

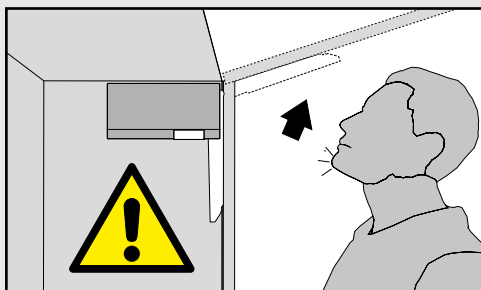

Verletzungsgefahr durch hochspringende Front!  
Front can spring upwards, causing injury!  
Risque de blessure en cas de relevage brusque de la face !  
Pericolo di lesioni a causa del possibile scatto verso l'alto del frontale!  
¡Peligro de lesiones por elevación del frente!  
Niebezpieczeństwo zranienia przez gwałtownie unoszący się front!  
Опасность травмы выскакивающим вверх рычагом!  
面板弹起会伤人!

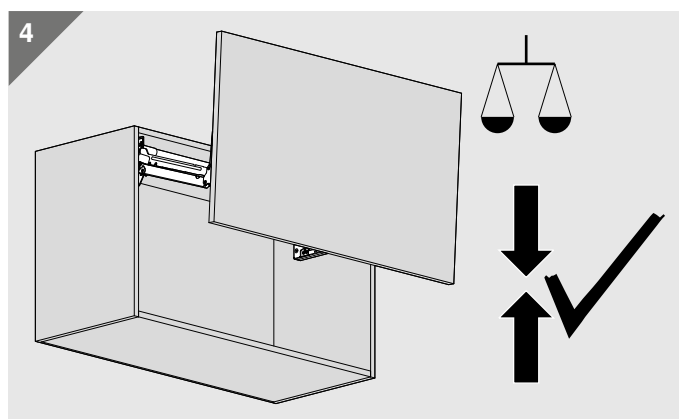
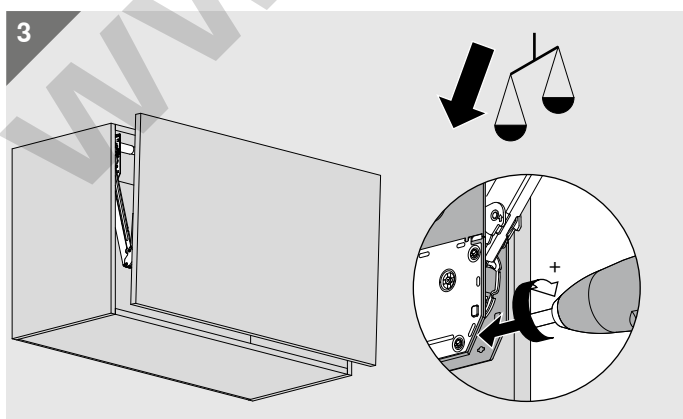
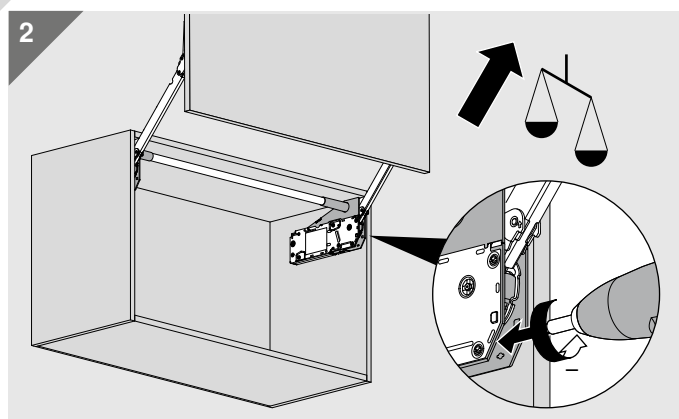
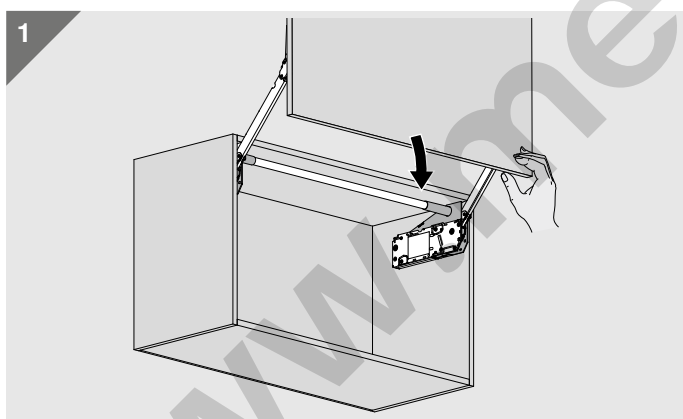
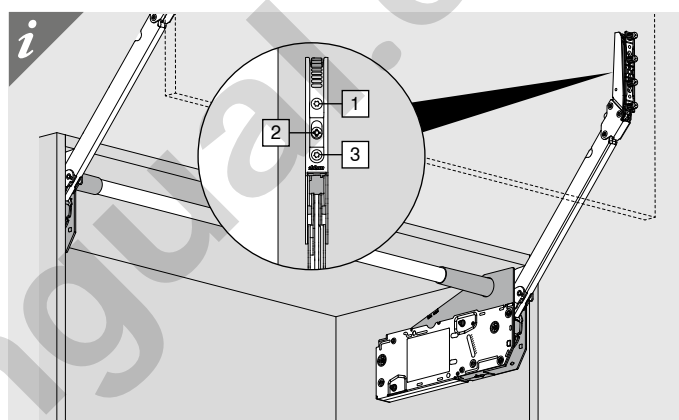
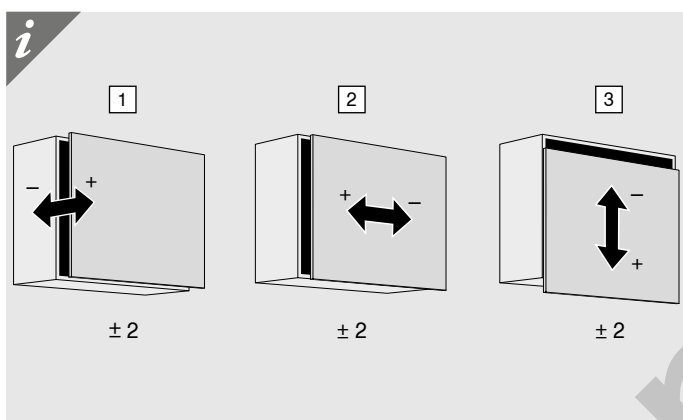

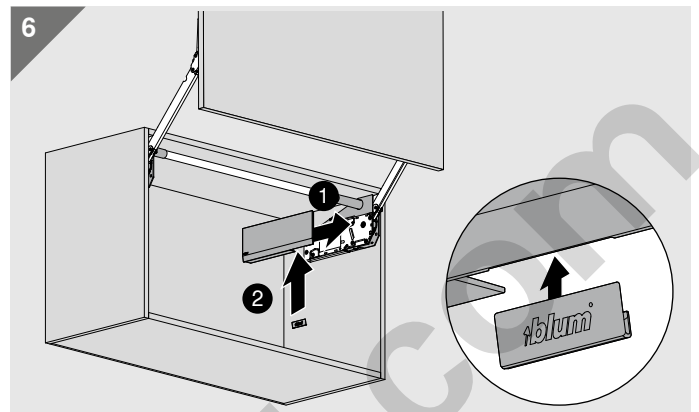
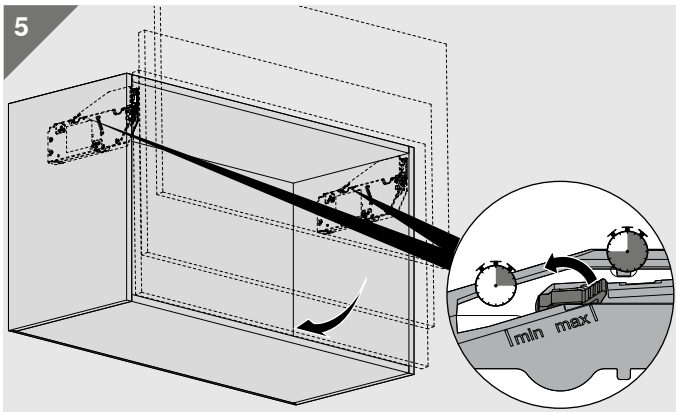

www.mengual.com

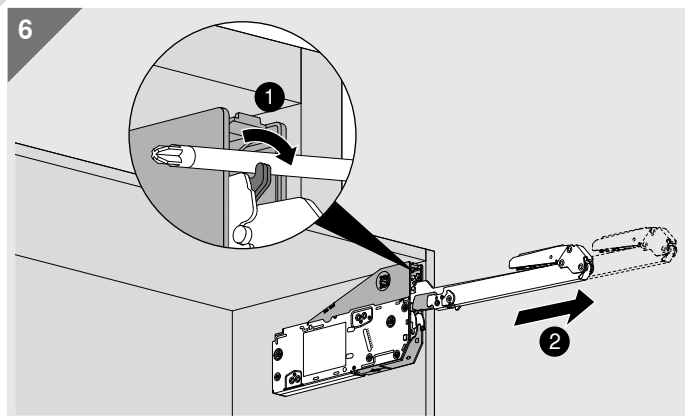
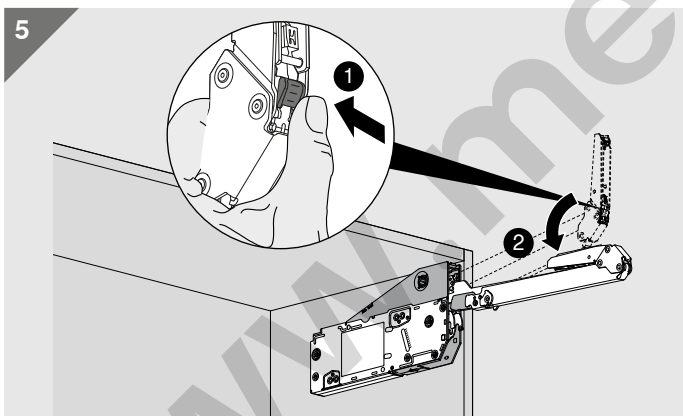
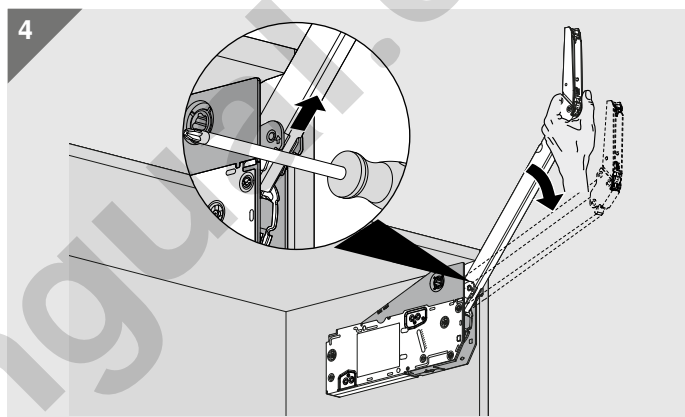
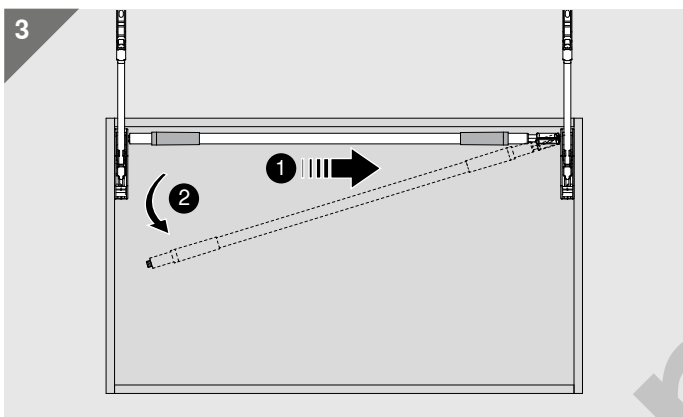
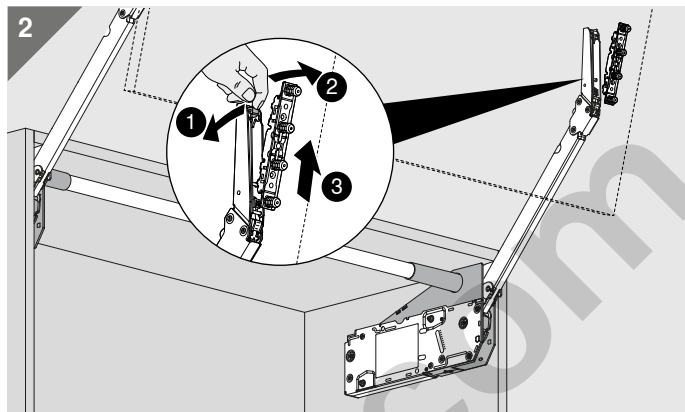
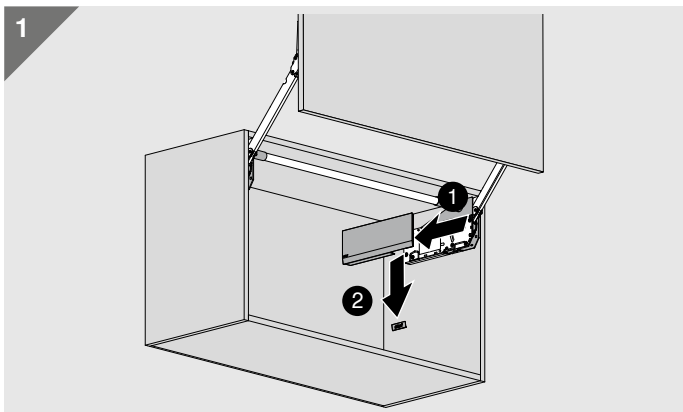





WARNUNG | WARNING | AVERTISSEMENT | AVVERTENZA |  
ADVERTENCIA | OSTRZEŻENIE | ВНИМАНИЕ | 警告

blum

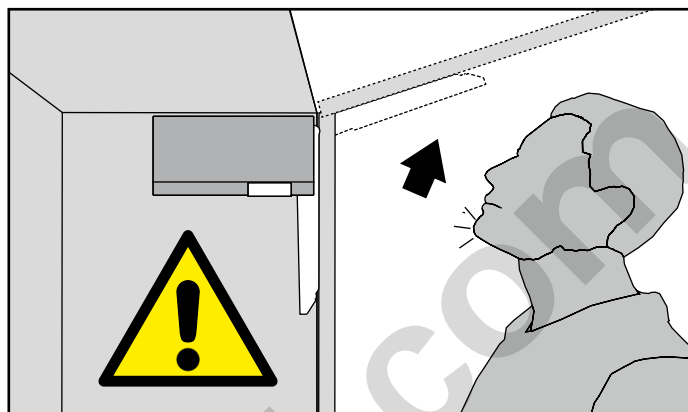
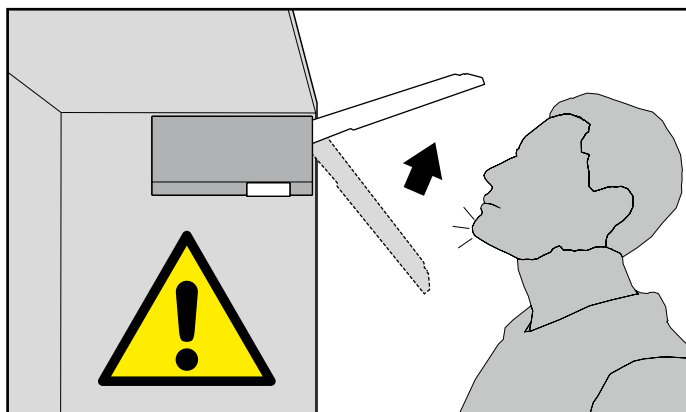

AR	هناك خطورة عندما يتحرك ذراع الرفع ربما يحدث إصابة
BG	Опасност от нараняване от повдигащото рамо!
CS	Nebezpečí zranění z důvodu vystřelujícího teleskopu!
DA	Risiko for at komme til skade ved opsvingning af løftestang!
DE	Verletzungsgefahr durch hochspringenden Hebel!
EL	Κίνδυνος τραυματισμού από τη συναρμολόγηση μοχλού με ελατήριο.
EN	Arms are under high tension and can spring upwards, causing injury.
ES	Peligro de lesión por elevación de la palanca.
ET	Ettevaatust – vinnastatud hoob liigub ülesse.
FI	Loukkaantumisvaara – varsi voi ponnahtaa ylös!
FR	Risque de blessure par la remontée rapide des bras !
HR	Opasnost od ozljeda uslijed teleskopske poluge koja iskače !
HU	Sérülésveszély a felugró emelőkar által!
IT	Rischio di ferimento in caso di scatto della leva verso l'alto!
HE	זרוע ההרמה עלולה לקפוץ כלפי מעלה ולגרום לפציעה.
JA	アームが跳ね上がって重傷を負う可能性があります。
LT	Traumos rizika montuojant mechanizmo svertą!
LV	Iespējams gūt traumas ar atsperoto atbalsta sviru!
NL	Risico tot kwetsuren door omhoogverende hefboom!
NO	Fare for skade ! Kraftig fjærpakke!
PL	Niebezpieczeństwo zranienia przez gwałtownie unoszący się podnośnik!
PT	Perigo de ferimento, devido ao brusco salto da alavanca
RO	Pericol de rănire prin părgăhia aflată sub tensiunea produsă de arcuri!
RU	Существует опасность получения травмы при выскакивании рычага!
SK	Nebezpečnosť poranenia vyskočením ramena!
SL	Nevarnost poškodbe pri montažiдвиžnega vzvoda.
SR	Opasnost od povreda zbog teleskopske poluge koja iskače !
SV	Skaderisk vid obelastad lyftarm!
TR	Kolun yukarı fırlaması durumunda yaralanma tehlikesi!
UK	Загроза травмування з причини різкого піднімання важелю!
ZH	伸缩臂上弹会伤人!